

OtO Photonics

Pocket Hawk - Near-infrared (PH-NIR) Series Product sheet



Description

PH-NIR Series spectrometer is built with the InGaAs linear array sensor and 32bits RISC controller. By simplification of the optical engine and specific sensor, the further miniaturized spectrometer is achieved. External MB type of PH-NIR Series can be chosen to enhance heat dissipation. The compact size and various of screw holes is very flexible for system integration.

PH-NIR Series spectrometer is constructed by the Crossed Czerny-Turner optical design and can provide the high optical resolution, high sensitivity, low stray light, and fast spectral response.

The electronics system is powered by USB port and PH-NIR Series communicates with the PC through the USB port. It also provides 8 pin or 4pin I/Os for external interface extension.

PH-NIR Series electronics operation is controlled by the RISC controller. So the user can communicate to the main program through the PC software and the protocol provided by OtO Photonics.



- This Document is for business promotion use only.
- For customer's Specification Approval or IQC need, we will provide official Approval Sheet.

OtO Photonics

Pocket Hawk - Near-infrared (PH-NIR) Series

Attention

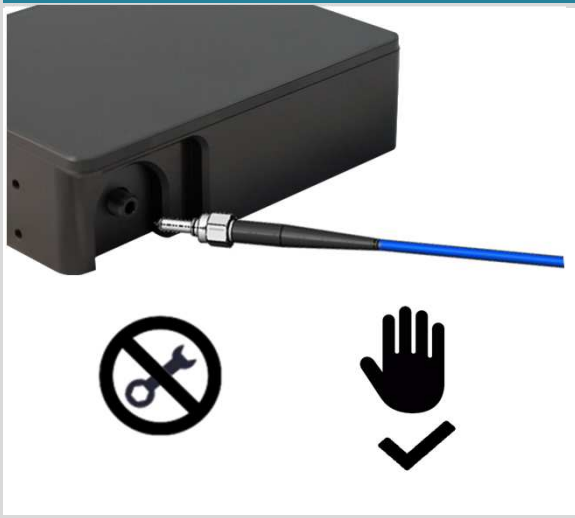
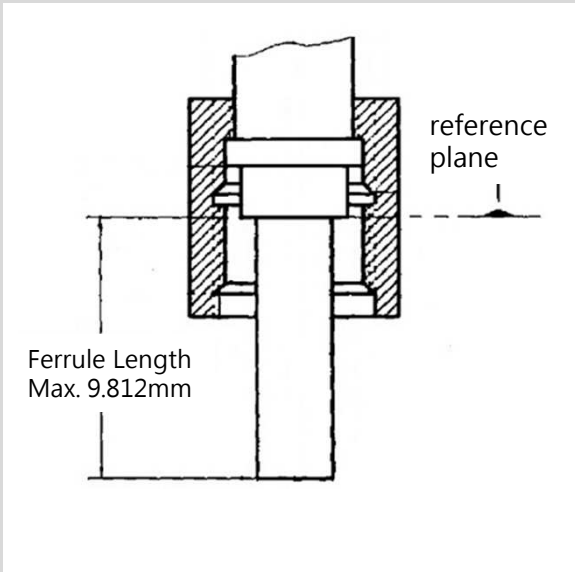
Picture	Description
	<p>To prevent over tightening and <u>damaging of the slit</u> in the spectrometer. Please <u>Hand tightening</u> the optical fiber only. Do not use any tool including wrench to tighten up the optical fiber and SMA905 connector.</p> <p>Apply adhesive to optical fiber connector after hand tightening is recommended if the fiber needs to be fixed robustly for a long time operation.</p>
	<p>Due to the design of SMA905 connector of spectrometer is based on <u>IEC 874-2:1993</u> and to prevent <u>damaging of the slit</u> in the spectrometer, please note the ferrule length of SMA905 Optical fiber must shorter than 9.812mm.</p>



OtO Photonics

Pocket Hawk - Near-infrared (PH-NIR) Series

■ Main Features

1.1	Feature	P4
1.2	Specification	P5
1.3	Wavelength response	P7
1.4	Lineup of PH-NIR	P7

■ Structure

2.1	Mechanical Diagram	P8
2.2	Electrical Pinout	P9
2.3	Sensor Overview	P12

■ Internal Operation

3.1	Pixel Definition	P15
3.2	Digital Inputs & Outputs	P15

■ USB Port Interface Communications and Control Information

4.1	Overview	P16
-----	----------	-----



OtO Photonics

Pocket Hawk - Near-infrared (PH-NIR) Series

■ Main Features

▶ 1.1 Feature

- Wavelength range : from 900 to 1700 nm
- Optical resolution (PH25x4): from 5 to 30 nm, depending on the combination of various slits and gratings
- InGaAs linear array sensor
- Modular configuration with various slit options
- Integration times from 100μs to 15sec
- 16 bit, 15MHz A/D Converter
- Micro USB 2.0 @ 480 Mbps (High speed)
- 4pin customized USB connector
- 8-pin connector for interfacing to external
 - ▣ 6 user programmable digital I/O
- Plug-n-play interface for PC application
- Extremely precise continuous multiple exposures, providing up to 4,000 spectra buffering
- Flash ROM storage for
 - ▣ Wavelength Calibration Coefficients
 - ▣ Linearity Correction Coefficients
 - ▣ Intensity Calibration Coefficients

OtO Photonics

Pocket Hawk - Near-infrared (PH-NIR) Series

► 1.2 Specification

SPEC		Content	
		PH2524	PH2534
Sensor		InGaAs linear sensor 128 Pixels	InGaAs linear sensor 256 Pixels
Parameters of Optical System		f/# : 4.5, NA :0.11, Focal Length(R1-R2) :39-44 (It is recommended that the Incident NA should larger than the NA of spectrometer.)	
Dark Noise (Upper Limit)	High Gain	15	
	Low Gain	NA	
Dynamic Range (avg.)*1	High Gain	6250	
	Low Gain	Na.(>7200)	
SNR (Single acquisition)	High Gain	2000	
	Low Gain	6000	
Spectrometer		Crossed Czerny-Turner Optical Structure 2nd & 3rd order rejection	
Dimension		65(L) x 65(W) x 29.8(H) mm	
Grating		2 grating options	
Wavelength		900-1700nm	
Slit Size		50, 100, 200 um	
Integration Time		100μs ~ 15 sec , depending on the sensor type	
Wavelength Repeatability		+/- 0.2 nm (Argon lamp 100 times)	
Wavelength accuracy		<± 1.5nm	
Resolution(FWHM)		From 5 nm to 30 nm, depending on different configuration	
Thermal Stability		<0.069nm/°C	
Environment Conditions	Storage	-30°C to +70°C	
	Operation	0°C to +50°C	
	Humidity	0% - 90% non-condensing	

*1 : 65535/Dark Noise(average)

- This Document is for business promotion use only.
- For customer's Specification Approval or IQC need, we will provide office Approval Sheet.



OtO Photonics

Pocket Hawk - Near-infrared (PH-NIR) Series

Interfaces	Micro USB 2.0 @ 480 Mbps (High speed)
Input Fiber Connector	SMA905: $\Phi 3.20 \pm 0.01 \text{mm}$
Recommend Tightening Torque	0.15 Nm (Mating Part : 5mm thick, Flatness 0.1mm, Aluminum sheet)
Power	Supply voltage: 4.75V-5.25V

- This Document is for business promotion use only.
- For customer's Specification Approval or IQC need, we will provide office Approval Sheet.

OtO Photonics

Pocket Hawk - Near-infrared (PH-NIR) Series

► 1.3 Wavelength Response

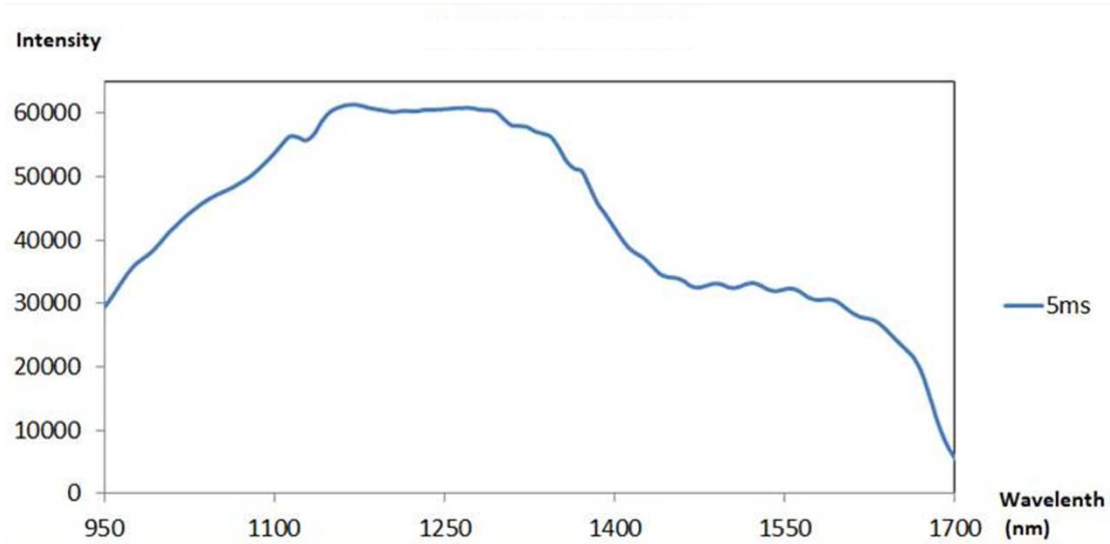

Fig. 1: PH2524 Wavelength Response

► 1.4 Lineup of PH-NIR Series

Model	Spectral Response Range (nm)		Sensor	SNR ^{*1}		A/D	Stray Light	Thermal Stability
	NIRC1/C2			Low Gain Mode	High Gain Mode			
	900	1700						
PH2524 /PH2534	√		InGaAs Sensor	6000	2000	16 bits	<0.2%	< 0.069nm/°C

*1 : Single acquisition

OtO Photonics

Pocket Hawk - Near-infrared (PH-NIR) Series

■ Structure

▶ 2.1 Mechanical Diagram

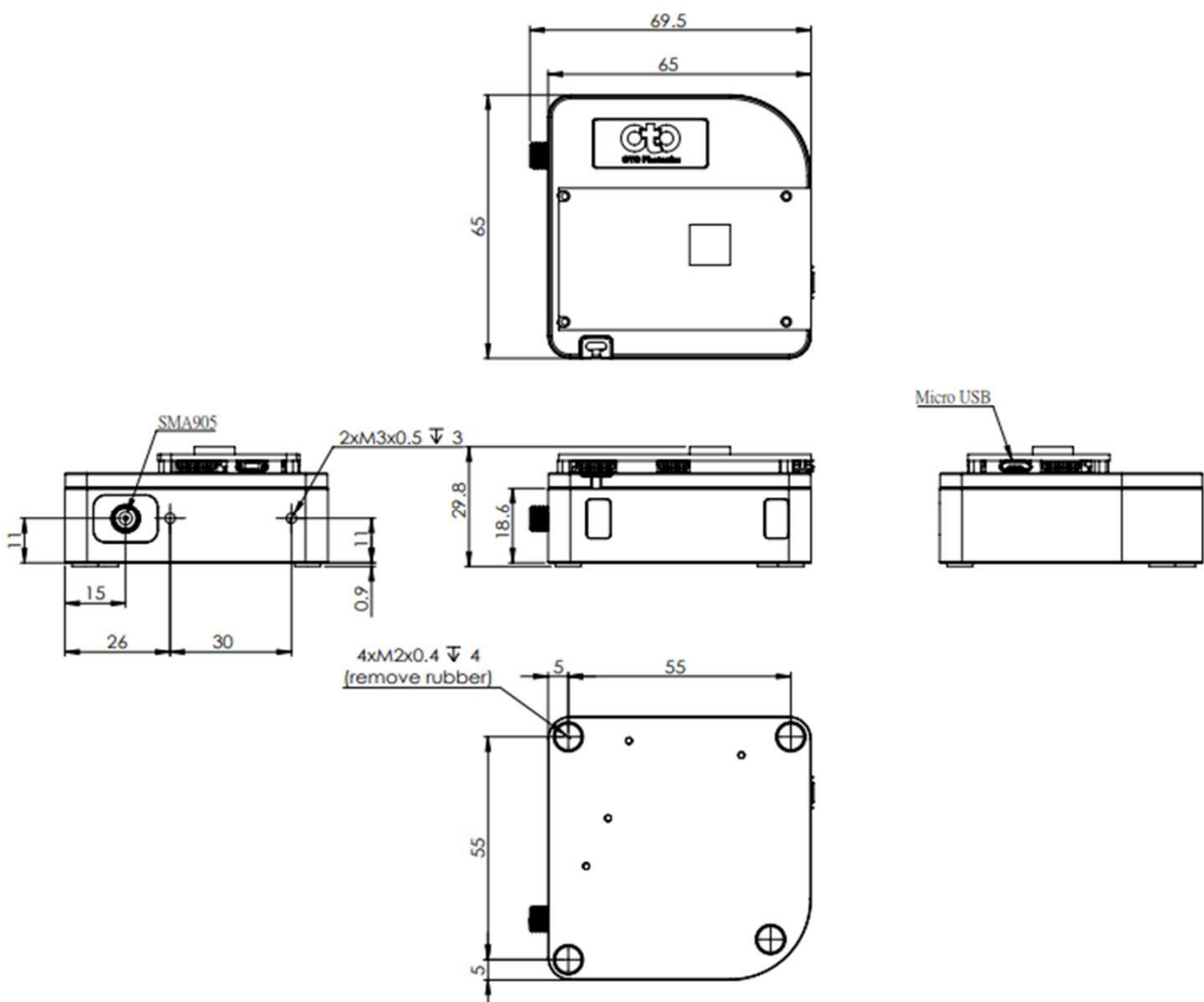

Fig. 2: PH-NIR outer dimensions

OtO Photonics

Pocket Hawk - Near-infrared (PH-NIR) Series

► 2.2 Electrical Pinout

The following listed is the pin description for the PH-NIR Series Extension Connectors. There are two Extension Port (8 pin 1.0mm connector for GPIO, one of them is for OtO debug use), one Micro USB, one USB(4 pin, for special use)

● Pin orientation

Looking PH-NIR Series connector side, from right to left are GPIO Extension Port, Micro USB, USB

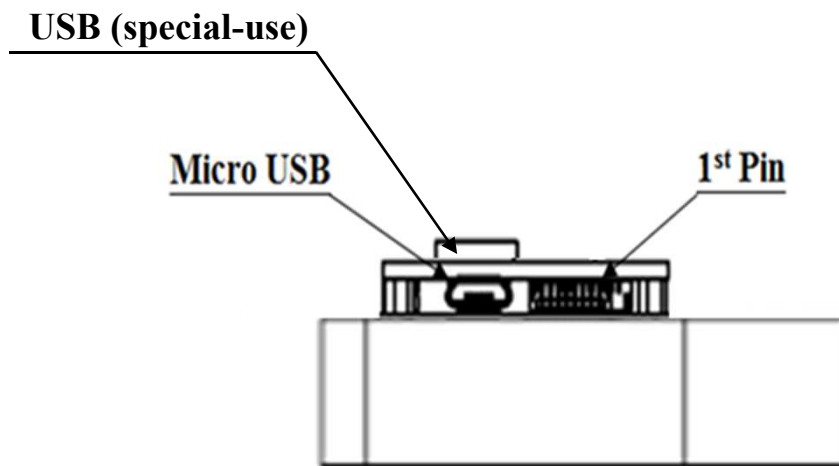

Fig. 3 : PH-NIR Series: the front-view of connector mechanical graph

OtO Photonics

Pocket Hawk - Near-infrared (PH-NIR) Series

Back Extension Port Pin# Description Alt Function

*All I/Os are TTL-level input/output

Pin No.	Direction	Pin Name	Function Description
1	Power	3.3V	This pin can provide around 0.1A power for external device.
2	Output	TX	UART TX. TX is the output from the RISC controller.
3	Input	RX	UART RX. RX is the input for the RISC controller.
4	Output	GPIO0	General Purpose Output 0.
5	Output	GPIO1	General Purpose Output 1.
6	Output	LS_ON	Light Source Turn ON.
7	Input	Trigger_IN	External Trigger Input Signal.
8	GND	GND	GND

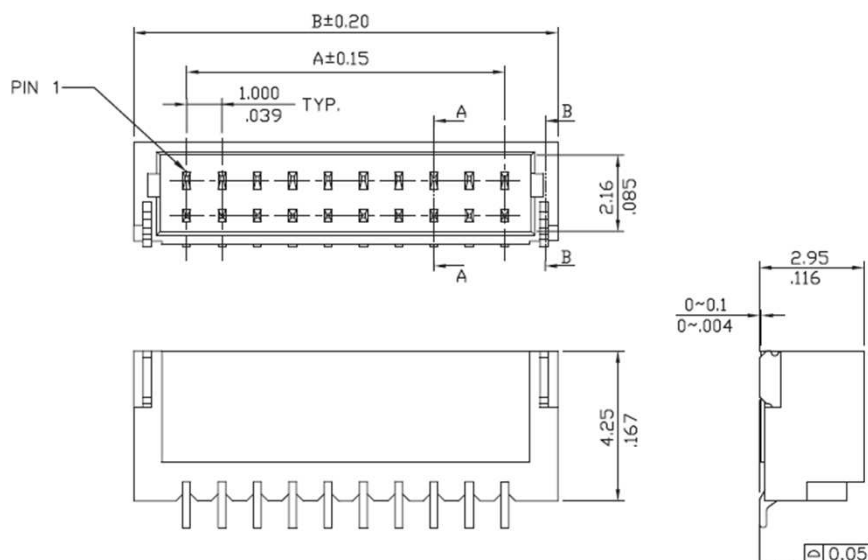

Fig. 4 : Back Extension Port 1.0 mm 8 pin drawing

- This Document is for business promotion use only.
- For customer's Specification Approval or IQC need, we will provide office Approval Sheet.

OtO Photonics

Pocket Hawk - Near-infrared (PH-NIR) Series

USB Port (Special –use)

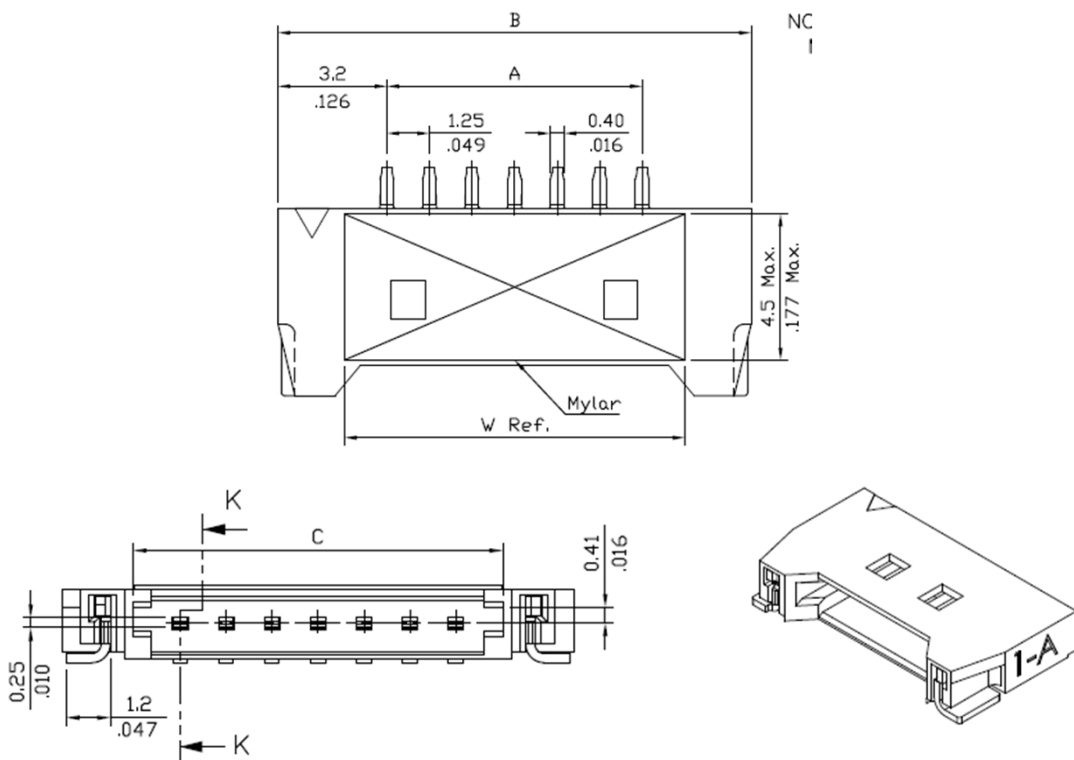

Fig. 5: USB(Special-use) 1.0 mm 4 pin drawing

□ Pin# Description

Pin No.	Direction	Pin Name
1	+3.3V	+3.3V
2	Data-	USB-
3	Data+	USB+
4	GND	GND

OtO Photonics

Pocket Hawk - Near-infrared (PH-NIR) Series

► 3.5 Sensor Overview

● InGaAs DETECTOR

InGaAs sensor is high sensitive in NIR region. The linear array type is suitable for quick and accurate spectrum measurement. A built-in timing generator and clock-drivers ensure single 5V power supply for use.

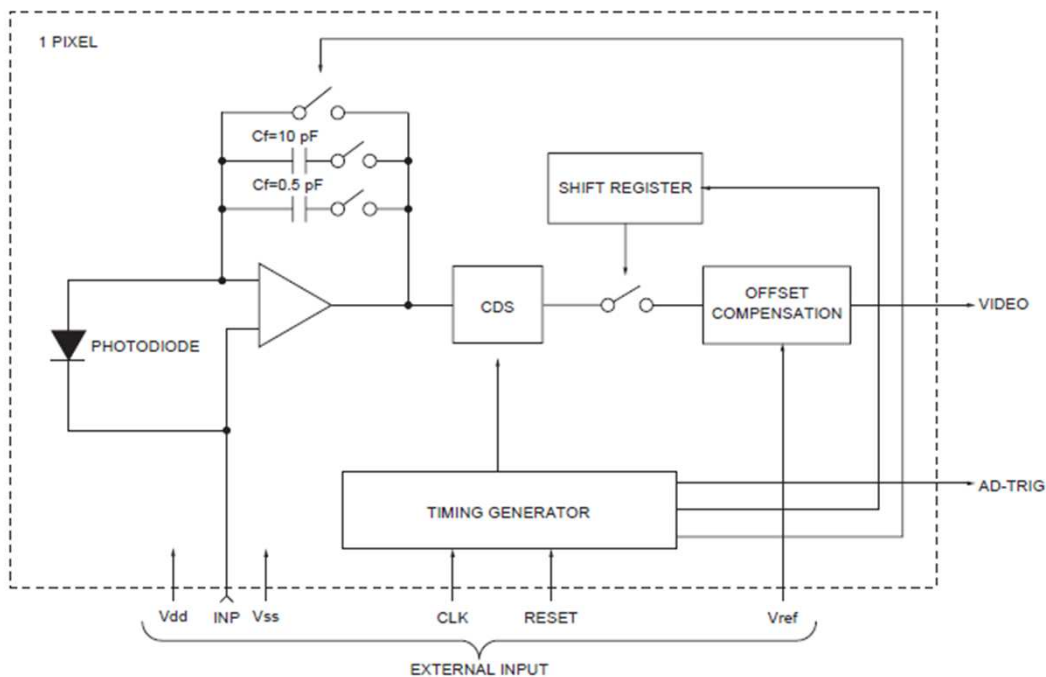

Fig. 6: InGaAs Sensor Block Diagram

OtO Photonics

Pocket Hawk - Near-infrared (PH-NIR) Series

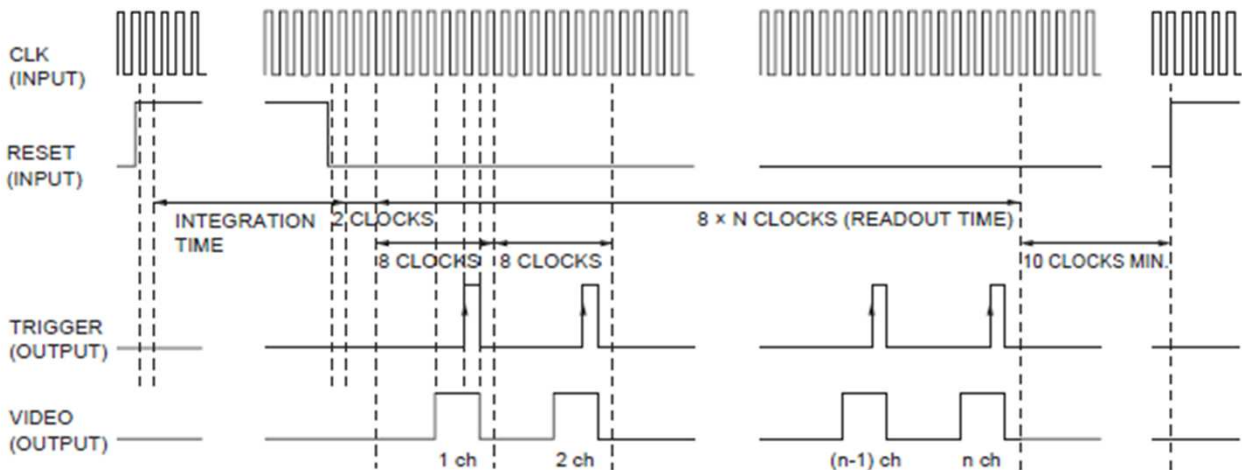

Fig.7: InGaAs sensor operation timing waveform

The output signal is proportion to the integration time. When the light power or integration time is long enough to fully charge the pixel, the sensor output will be saturated. Per the characteristic of the sensor, the over-saturated condition may cause the abnormal response.



OtO Photonics

Pocket Hawk - Near-infrared (PH-NIR) Series

● **CCD/SYSTEM NOISE**

There are three major sources impact the Vout signal reading. One is the light source stability, the second is the electronics noise, and the other is CCD detector noise. If we don't consider the outer light source influence, we can check the dark noise performance of this system first. The dark noise we define here is the RMS of Vout signal under 1ms integration time in dark condition. So the dark noise will be only contributed by electronics readout noise and the CCD sensor.

The other major parameter to define the noise performance is the SNR. The SNR we define here is the ratio of the full signal (65535 counts) to the RMS value under the full signal condition. The higher SNR performance indicates the readout signal is more stable. It will be helpful for the low signal differentiation.

● **SIGNAL AVERAGING**

The software-SpectraSmart provides two options for the signal curve operations. The first one is the signal averaging. By the averaging method, we can reduce the noise impact on each pixel. Surely, more sampling points will bring the better averaging performance. But it will need more time to get one spectra. When we use the time-base type of signal averaging, the S:N increases by the square root of the number of samples. Thus, a S:N is readily 10x achieved by averaging 100 spectra.

The other curve smoothing is boxcar filter. It can average the adjacent points to show the smoother curve, but it will lower optical resolution. So if the target signal is peak type, the boxcar may not be suitable for this.

These two methods can be enabled at the same time if the measurement target is suitable for this operation. But if the user would like to check all the original data and performance, time-based average or boxcar smoothing needs to be un-checked. The default setting for these two average methods is un-checked.

- This Document is for business promotion use only.
- For customer's Specification Approval or IQC need, we will provide office Approval Sheet.

OtO Photonics

Pocket Hawk - Near-infrared (PH-NIR) Series

Internal Operation

3.1 Pixel Definition

The baseline signal is around 1,000 counts in our current system. We can provide the tool/command to manually adjust the baseline. (adjust the AFE OFFSET) The other baseline adjustment method is to enable the background removal from the software. It depends on the user how to use the baseline. Normal output signal is not obtained immediately after device switch on. Use the output signal added 22500 pulses or above to CLK clock pulse.

- The following is a description of all of the pixels

Pixel	Description
1–13	Dummy pixels
14–31	Optical black pixels
32	Dummy pixels
33–3032	Optical active pixels
3033-3038	Dummy pixels

3.2 Digital Inputs & Outputs

General Purpose Inputs/Outputs (GPIO)

PH-NIR Series has 6 user programmable 3.3V digital Input/Output pins, which can be accessed at the 8-pin Extension connector. Through software, the state of these I/O pins can be defined and used for multi-purpose applications. If the user needs the special timing generation (like single pulse or PWM), PH-NIR Series provides the flexibility to implement this.



OtO Photonics

Pocket Hawk - Near-infrared (PH-NIR) Series

■ USB Port Interface Communications and Control Information

▶ 4.1 Overview

PH-NIR Series is a microcontroller-based Miniature Fiber Optic Spectrometer that can communicate via the Universal Serial Bus. This section contains the necessary programming information for controlling PH-NIR Series via the USB interface. This information is only pertinent to users who wish to not utilize SpectraSmart software to interface to PH-NIR Series.

● Hardware Description

PH-NIR Series utilizes a 32 bit RISC controller built in USB 2.0. Program code and data coefficients are stored in SPI Flash. The RISC controller supports 32 MByte DDR and 64 Mbits Flash.



OtO Photonics

Pocket Hawk - Near-infrared (PH-NIR) Series

● INSTRUCTION SET

Application Programming Interface

The list of the APIs is shown in the following table followed by a detailed description of each function call.

□ Open PH-NIR Series Spectrometer

Description: To connect Windows host to PH-NIR Series

a.Function Name: UAI_SpectrometerOpen

b.Arguments:

dev: 8 PH-NIR Series spectrometers can be attached to one host at the same time. dev is the device number to specify which one will be opened.

handle: the unique Windows identifier to operate devices. Windows will return the identification number which is necessary for further operation.



OtO Photonics

Pocket Hawk - Near-infrared (PH-NIR) Series

□ Query Frame Size

Description: To get the data frame size of the spectrometer.

a.Function Name: UAI_SpectromoduleGetFrameSize

b.Arguments:

device_handle: a pointer to the device information structure which is returned

when device open.

size: a 16-bit unsigned integer will be returned to indicate the data length.

□ Acquire Wavelength

Description: Initiates a wavelength acquisition. PH-NIR Series will acquire a complete wavelength distribution.

a.Function Name: UAI_SpectrometerWavelengthAcquire

b.Arguments:

device_handle: a pointer to the device information structure which is returned when

device open.

buffer: the storage buffer acquired data.



OtO Photonics

Pocket Hawk - Near-infrared (PH-NIR) Series

□ **Acquire Spectra**

Description: Initiates a spectra acquisition. PH-NIR Series will acquire a complete intensity distribution which corresponds to the wavelength which is acquired by OtO_UAI_SpectrometerWavelengthAcquire.

a. **Function Name:** UAI_SpectrometerDataAcquire

b. **Arguments:**

device_handle: a pointer to the device information structure which is returned when device open.

integration_time_us: a 32-bit unsigned variable to determine the integration time of the micro-seconds.

buffer: the storage buffer acquired data.

average: the spectrum could be averaged by several continuous acquisitions to reduce the noise.

□ **Query Wavelength Range**

Description: To get the minimum and maximum wavelength

a. **Function Name:** UAI_SpectromoduleGetWavelengthStart

Function Name: UAI_SpectromoduleGetWavelengthEnd

b. **Arguments:**

device_handle: a pointer to the device information structure which is returned when device open.

lambda: a 32-bit floating type data which is indicate the minimum or maximum wavelength, in nm, of PH-NIR Series will be returned.



OtO Photonics

Pocket Hawk - Near-infrared (PH-NIR) Series

❑ Query Integration Time Range

Description: To get the minimum and maximum integration time.

a.Function Name: UAI_SpectromoduleGetMinimumIntegrationTime

Function Name: UAI_SpectromoduleGetMaximumIntegrationTime

b. Arguments:

device_handle: a pointer to the device information structure which is returned when

device open.

Integration Time: a 16-bit integer type data which indicates the minimum or maximum integration time of PH-NIR Series will be returned. The minimum integration

time is in micro-second and the maximum Integration time is in milli-second.

❑ Close PH-NIR Series Spectrometer

Description: To connect Windows host to PH Series

a.Function Name: UAI_SpectrometerClose

b.Arguments:

handle: the unique Windows identifier to operate devices. Windows will detach

the device and any operation is invalid after this function is executed.